

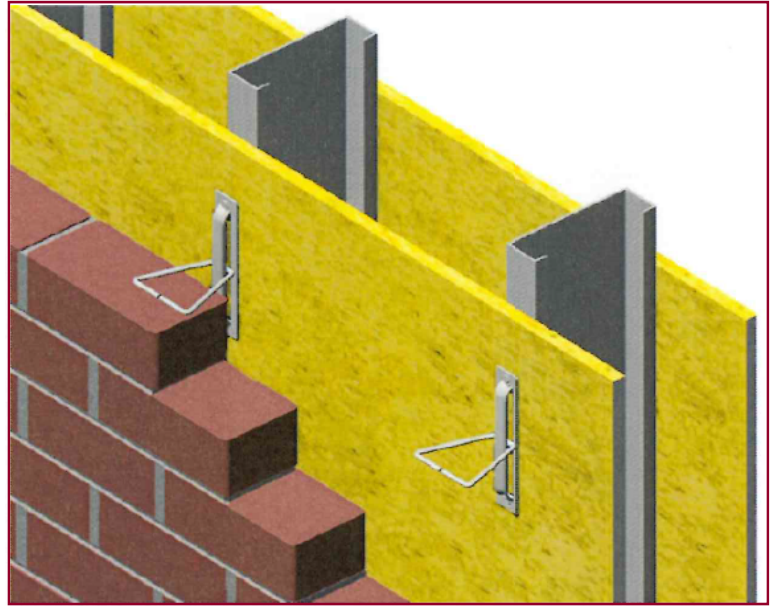

# PRODUCT SUBMITTAL

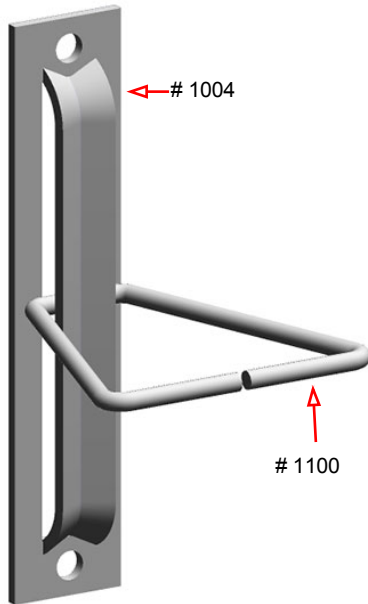

## # 1004 Type III Screw On Veneer Anchor



MATERIAL CONFORMANCE	SIZES / FINISHES
<p><b>ASTM A1064/A1064M, ASTM A82 / A82M</b> - (Cold drawn steel wire) Tensile Strength - 80,000 psi Yield Point - 70,000 psi</p> <p><b>ACI / ASCE 530</b> - (Building code requirements for masonry structures)</p> <p><b>SHEET METAL</b> - (Carbon Steel) <b>ASTM A1008 / A1008M</b></p> <p>Mill Galvanized / Zinc Coating: <b>ASTM A641 / A641M (0.10 Oz per sq ft)</b></p> <p>Hot Dip Galvanized after fabrication / Zinc Coating <b>ASTM A153 / A153M-B2 (1.50 oz per sq ft)</b></p> <p>Stainless Steel <b>ASTM 580 / ASTM 580M Type 304</b> (Type 316 available on special order)</p> <p style="text-align: right;"><b>Recycled Content:</b> Mill Galvanized &amp; Hot Dip, 82.8% Post-Consumer 17% Post Industrial / Pre - Consumer</p> <p style="text-align: right;">Stainless Steel, 60% Post Consumer V O C Content - 0%</p>	<p><b># 1004 Type III:</b> 1-1/4" wide x 6" long</p> <p><input type="checkbox"/> 14 gauge</p> <p><b># 1100 Triangle:</b></p> <p><input type="checkbox"/> 3/16" diameter</p> <p><input type="checkbox"/> 3"x3"   <input type="checkbox"/> 4"x4"   <input type="checkbox"/> 5"x5"   <input type="checkbox"/> 6"x6"   <input type="checkbox"/> 7"x9"   <input type="checkbox"/> 9" x 9"</p> <p><b>FINISH:</b></p> <p><input type="checkbox"/> Mill Galvanized</p> <p><input type="checkbox"/> Hot Dip Galvanized</p> <p><input type="checkbox"/> Stainless Steel</p> <div style="text-align: right;">  </div>



[www.wirebond.com](http://www.wirebond.com)

MASONPRO, Inc.  
43300 Seven Mile Road  
Northville, MI 48167  
1-800-659-4731  
[www.masonpro.com](http://www.masonpro.com)